

SGR Swing Gate Racks

EIA/TIA Compliant

Open swing-gate rack provides easy rear equipment access

Features

- Open wall mount design lets you swing equipment out to greatly simplify wiring tasks
- Innovative "positive stop" design facilitates punching down while fully open
- Tie points and Velcro cable loops included for cable routing
- Available in 2 depths: 12" and 18"
- 100 lb. weight capacity
- Durable black powder coat finish



SGR-20-18

Architects' and Engineers' Specifications

EIA/TIA compliant swing gate rack shall be Middle Atlantic Products model # SGR-x-y (x = # of rackspace, y = depth) (refer to chart). SGR shall be constructed of the following materials: back pan shall be 16-gauge steel, gate shall be 14-gauge steel, rackrail shall be 11-gauge steel with tapped 10-32 holes in universal EIA spacing. Swing gate rack shall have a 100 lb. weight capacity. SGR shall be finished in a durable black powder coat. SGR shall be warranted to be free from defects in material or workmanship under normal use and conditions for the lifetime of the product.

Engineered Mounting Solutions

US: New Jersey ■ California ■ Illinois ■ Voice: 973-839-1011 Fax: 973-839-1976 ■ middleatlantic.com
Canada: Ontario ■ British Columbia ■ Voice: 613-836-2501 Fax: 613-836-2690 ■ middleatlantic.ca

SGR basic dimensions

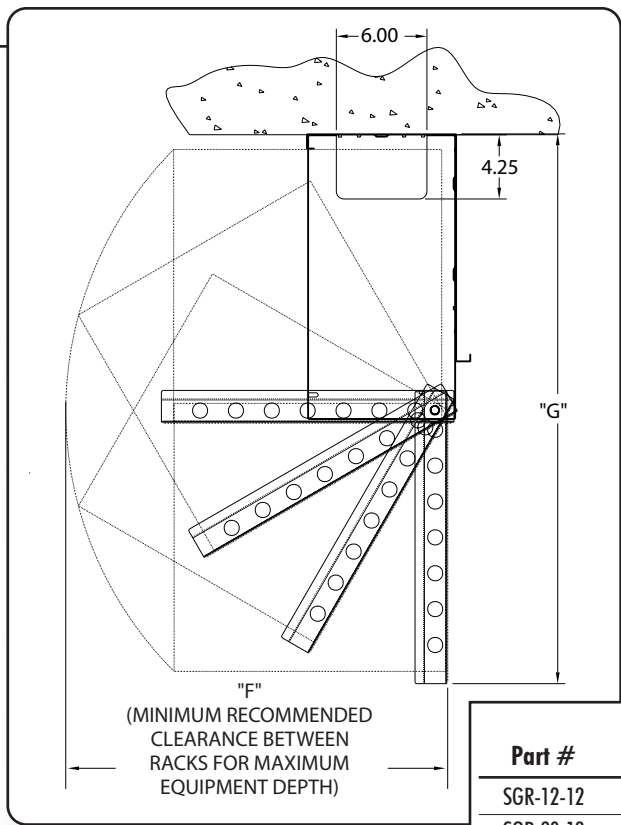
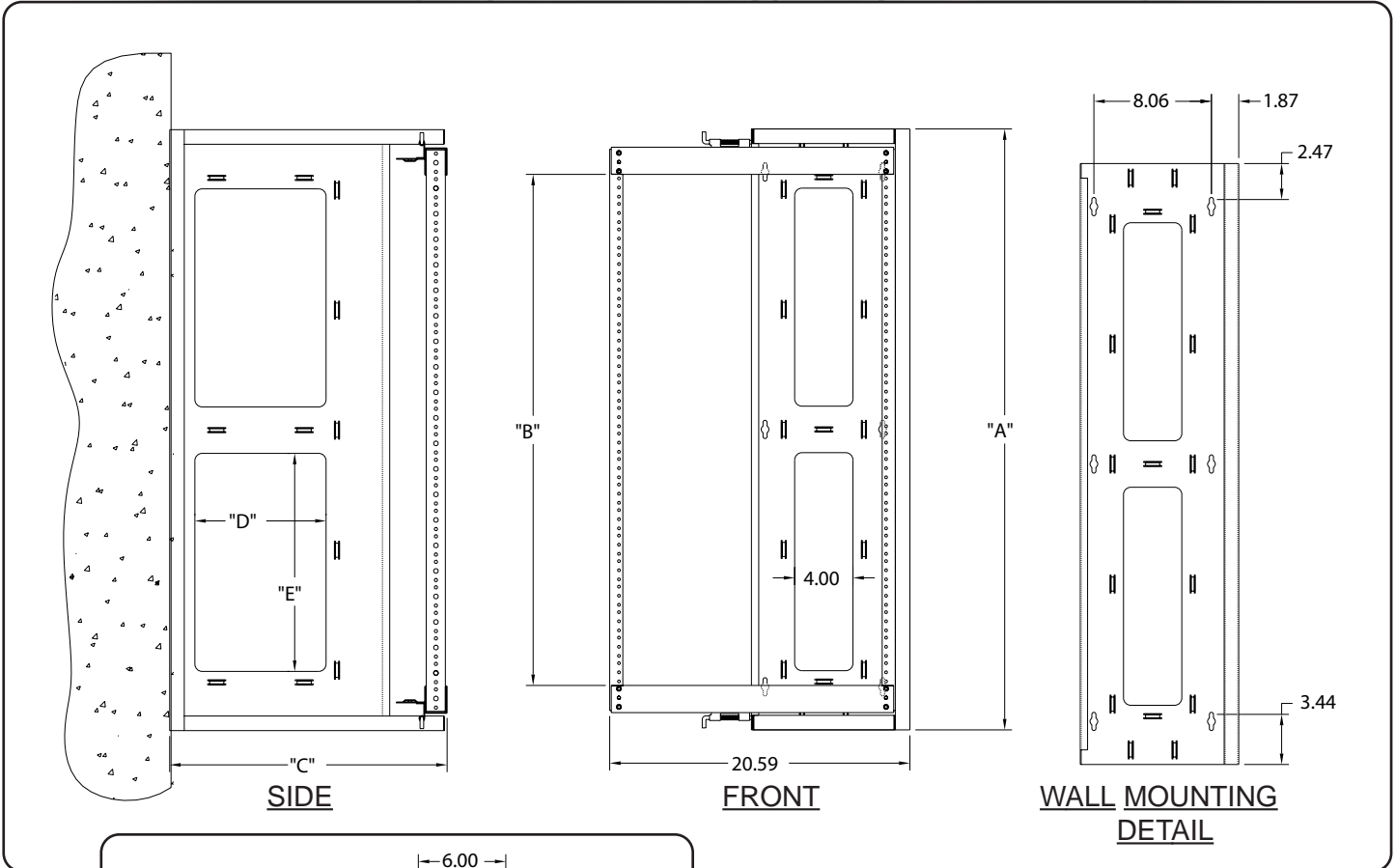

NOTE

| Part # | RACKING HEIGHT | | | | | | |
|-----------|----------------|--------------|-------|------|-------|-------|-------|
| | 'A' | 'B' | 'C' | 'D' | 'E' | 'F' | 'G' |
| SGR-12-12 | 27.22 | 21.00/ 12 SP | 13.03 | 3.00 | 7.95 | 23.25 | 30.41 |
| SGR-20-12 | 41.22 | 35.00/ 20 SP | 13.03 | 3.00 | 14.95 | 23.25 | 30.41 |
| SGR-12-18 | 27.22 | 21.00/ 12 SP | 19.03 | 9.00 | 7.95 | 27.12 | 36.41 |
| SGR-20-18 | 41.22 | 35.00/ 20 SP | 19.03 | 9.00 | 14.95 | 27.12 | 36.41 |